

ISOMETRIC VIEW
SCALE: 1:25

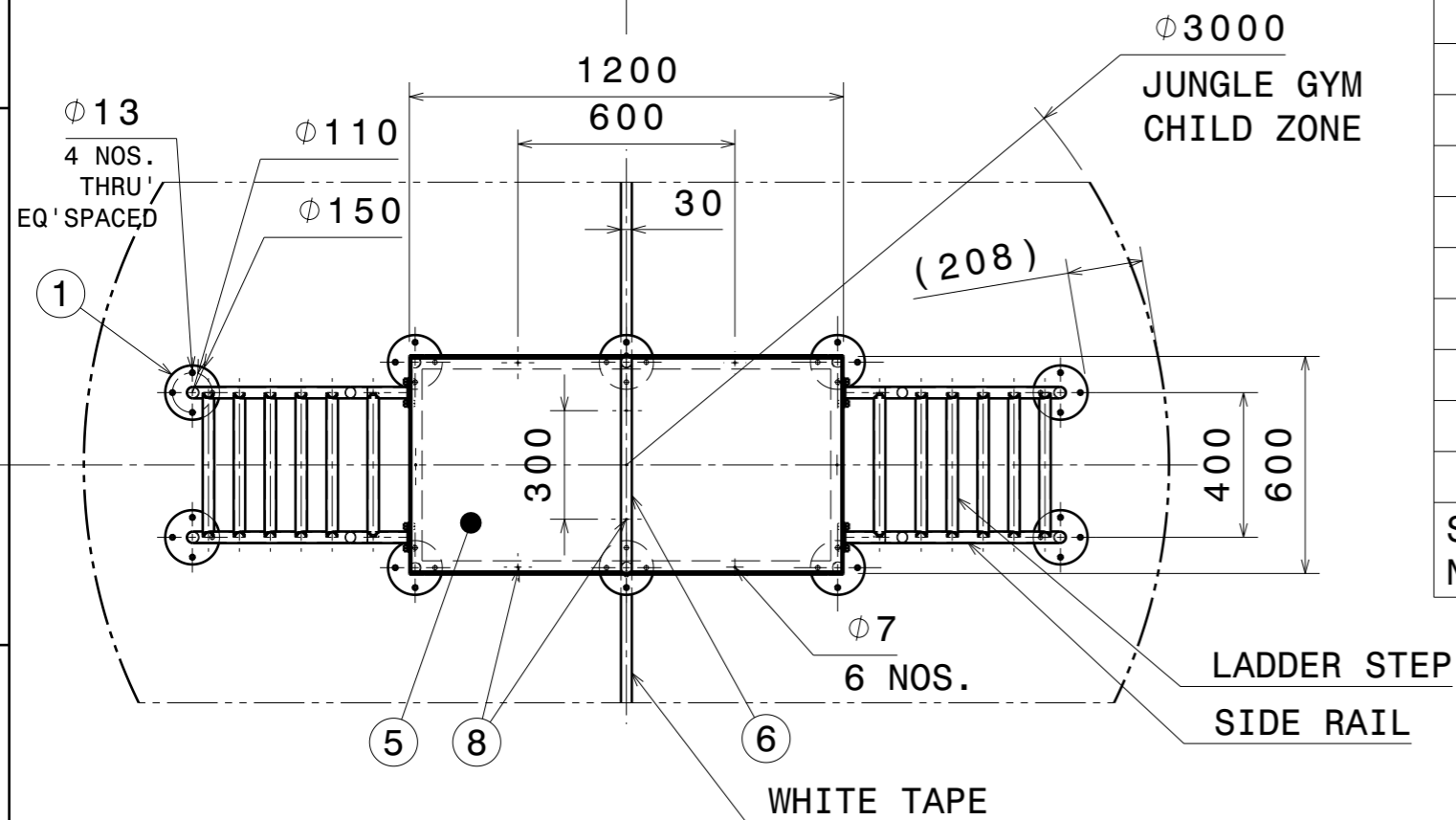

SR. NO.	ITEM DESCRIPTION	MATERIAL	QUANTITY	REMARK
10	HEXAGONAL NUT	STD	8	M10
9	HEXAGONAL BOLT	STD	8	M10 x 15L
8	WOOD SCREW	STD	11	Φ6 x 15 L
7	RAILING	MS	2 SETS	USING FLAT 10 x 3 THK.
6	PARTITION	PLYWOOD	1	FIXED WITH PLATFORM TOP
5	PLATFORM TOP	PLYWOOD	1	TO SUIT FRAME (INSIDE)
4	LADDER ASSY	MS	2 SETS	USING PIPE, Φ32, 2 THK.
3	FRAME	MS	1	35 x 35 x 5 THK. ANGLE
2	SUPPORT PIPE	MS	6	Φ32, 2 THK.
1	BASE PLATE	MS	10	Φ150 x 5 THK.

- NOTES:
- 1) ALL DIMENSIONS IN mm
 - 2) IT IS OPTIONAL TO WELD OR FASTEN LADDER ASSY TO THE FRAME
 - 3) ALL STRUCTURES TO BE PAINTED IN SILVER COLOR (EXCEPT FOR SPECIFIED SURFACES)
 - 4) ENSURE GOOD QUALITY OF WELDING WITH MIN. THROAT THK. 5 mm

DRAWN BY		DATE		DRAWING TITLE			
CHAITANYA		01/08/2013		FIG 6 - JUNGLE GYM			
CHECKED BY		DATE		SIZE	DRAWING NUMBER		REV
COMMITTEE		01/08/2013		A3	006		A
DESIGNED BY		DATE		SCALE	1:20	WEIGHT (kg)	--
COMMITTEE		01/08/2013				SHEET	1/1